

FXC970

Explosion proof
LED Floodlight

LEIZUR



Applications:

Typical applications include:

- Oil and gas industries
- Chemical, petrochemical
- Pharmaceutical industries
- Pulp and Paper
- Waste and sewage treatment
- Power Generation

Standard Materials:

- Housing: Die-casting aluminum
- Exterior: Stainless steel
- Globe: Tempered glass
- Gasket: Silicon rubber

Features:

- Zone 1&2, Zone 21&22
- Instant on crisp white light output
- High efficiency drivers and LEDs provide low-cost operation in harsh and heavy industrial applications.
- Isolated LED compartment reduces temperature within driver housing
- Multi choice of beam angle for 45° 90° 120°



FXC970



Explosion proof LED Floodlight

Specifications

Model	FXC9701	FXC9702	FXC9703	FXC9704
-------	---------	---------	---------	---------

Explosion protection

European (ATEX) Gas and Dust 	CE 1282 Ex II 2G Ex d IIC T6 CE 1282 Ex II 2D Ex td T80°C
For use in	Zone 1, 2 & Zone 21, 22

Electrical data

Rated voltage	100-240VAC, 50-60Hz
Power factor	>0.95
THD	<20%

Luminous characteristics

Power consumption [W]	20~80	100~120	150~200	250-300
Colour rendering [CRI]	70 (±2)			
Colour temperature [K]	5500-6000			
Luminaire efficiency [Lm/W]	120-130			
Beam angle	120° (45°, 90° is optional)			

Mechanical data

Degree of protection	IP66			
Cable entry	G 3/4"; NPT 3/4"			
Weight [kg]	5.12	9	12	16
Terminal	≤2.5 mm ²			
Mounting Styles	Ceiling; Wall Bracket; Pendant			

Installation

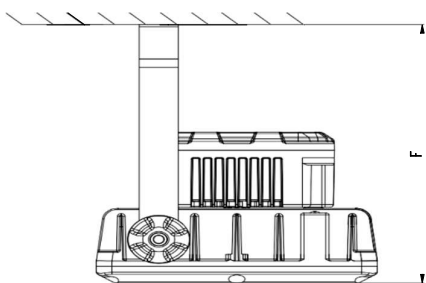

Ceiling Mount

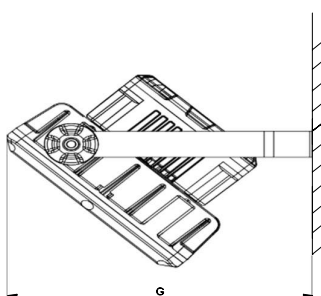

Wall Mount

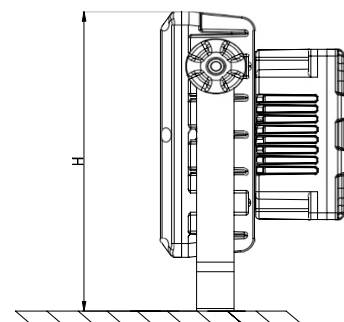

Bracket Mount

FXC970



Explosion proof LED Floodlight

Dimension [mm]

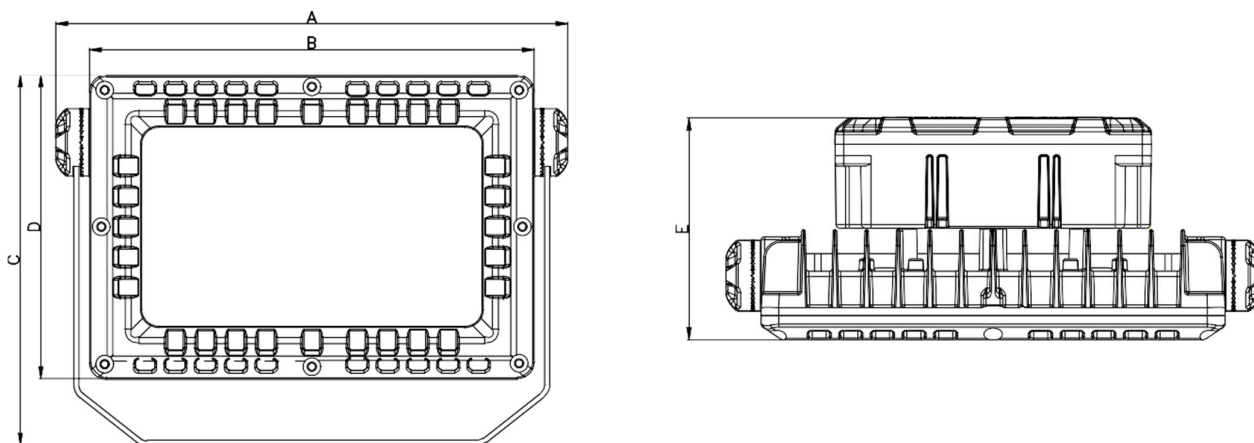

	A	B	C	D	E	F	G	H
FXC9701	304	264	219	180	126	216	227	219
FXC9702	384	344	273	240	126	255	277	273
FXC9703	472	418	315	275	130	295	320	315
FXC9704	544	492	371	330	130	341	374	371

FXC9701 Bracket	
FXC9702 Bracket	
FXC9703 Bracket	
FXC9704 Bracket	